

Küba Green Line



Küba market plus SP



High Performance Unit Cooler

<p>Q_0</p> <p>1,2  52 kW</p>	<p>+10 °C</p> <p>±0 °C SPA.D</p> <p>-25 °C SPB.D</p> <p>t_{1}</p> 		<p>EUROVENT CERTIFIED PERFORMANCE</p> <p><i>applied for</i></p> <p>"CERTIFY ALL" Air Coolers</p>
--	--	--	--



Application Benefits for Contractors and Operators



Expanded capacity range

- Up to 52 kW

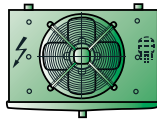

- 250 mm
- 300 mm
- 400 mm
- 500 mm

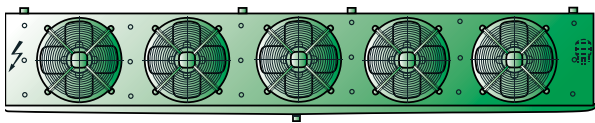

Closer-spaced capacity steps

- Thanks to five different fan sizes

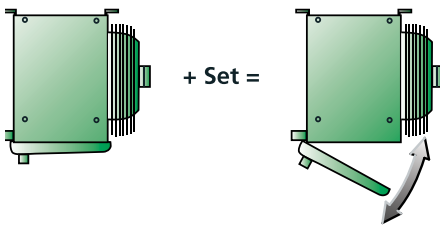

Quick cleaning

- Hinged drain tray as accessory (can be retro-fitted)

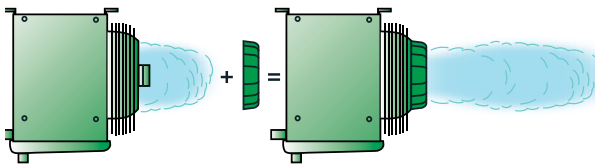

Increased air throw

- Küba Air Jet as accessory

Nomenclature

Standard

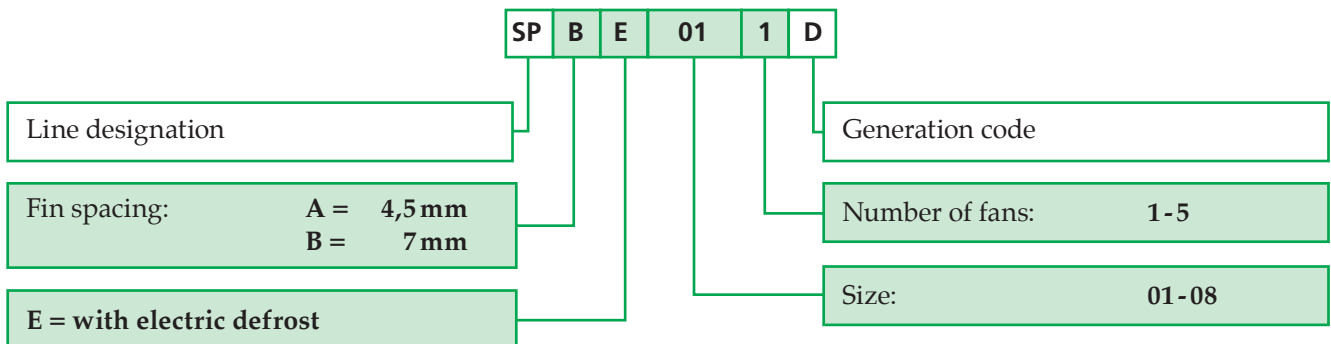



Construction

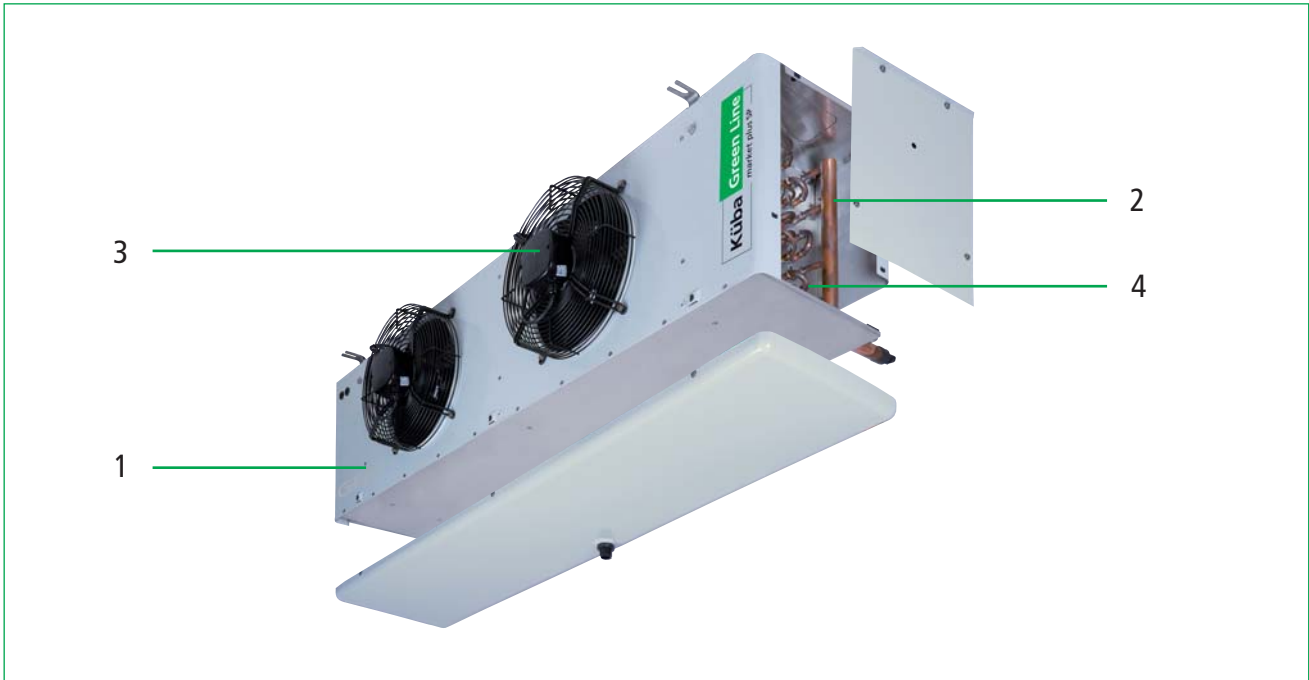

1. Casing

- Aluminium, smooth
- High-quality powder coating, papyrus white RAL 9018
 - Food-safe
 - Easy to clean
 - Best corrosion protection
- Removable side pieces

2. Cooler

- Internal cleanliness acc. to DIN 8964
- Fin spacing: SPA.D: 4,5 mm, SPB.D: 7,0 mm
- Refrigerant distributor:
 - SPA.D: Flow distributor
 - SPB.D: Küba-CAL®
- Tubing Cu-Special, Fins Al, End plates Al

3. Fans CE

- Fans wired up to an internal terminal box
- Ø 250 mm / Ø 300 mm / Ø 400 mm / Ø 500 mm
- With built-in protector according to VDE provisions (Ø 500 mm: Led-out protector wired up in parallel)
- Application range: RT: -30 °C bis +50 °C
- Voltage:
 - SP. 011 – 065D = 230 V ±10 %, V-1 50/60 Hz, adjustable
 - SP. 071 – 084D = 400 V ±10 %, V-3 50/60 Hz

- Index of protection acc. to DIN 40050:

- SP. 011 – 024D = IP42
- SP. 031 – 065D = IP44
- SP. 071 – 084D = IP54

- Insulation class acc. to VDE 0700

- SP. 011 – 065D = Insulation class B
- SP. 071 – 084D = Insulation class F

- Operating values are the actual values of the built-in motor at +20 °C, with unobstructed air flow and a dry surface, as required for the refrigeration load calculation

Motor label data (max. allowable value +40 °C)

	Ø mm	50 Hz			60 Hz		
		min ⁻¹	W	A	min ⁻¹	W	A
SP.01.-02.D	250	1300	90	0,62	1550	80	0,55
SP.03.-04.D	300	1340	80	0,36	1460	112	0,48
SP.05.-06.D	400	1420	188	0,83	1630	270	1,20
SP.07.-08.D	500	1350	565	1,13	1450	830	1,50

4. Electric defrost

- Wired-up, ready to connect in terminal box
- The heater rods are mounted in special tube sleeves for rapid and even defrosting
- 230 V-1 / 400 V-3-Y
- With splash pan



Technical data

SPA(E)...D



1,6 kW 52 kW

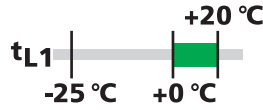

Model	Rating Q_0 at 50 Hz DT1, R404A		Surface m ²	Air flow m ³ /h	Air throw m	Tube volume dm ³	Connections		Sound L_{WA} ...	Blade St. x Ø mm	Fans Φ (Operating values at 50 Hz)			
	$t_{L1} \pm 0 \text{ °C}$ DT1 = 8K	$t_{L1} +10 \text{ °C}$ DT1 = 10K					Inlet Ø mm	Outlet Ø mm			Type of current	Per Fan min ⁻¹ W A		
SPA 011D	1,65	2,44	6,9	820	4	1,4	10	12	63	1 x 250	230V -1	1347	85	0,59
SPA 021D	1,80	2,65	9,1	760	4	1,9	10	12	63	1 x 250	230V -1	1347	85	0,59
SPA 031D	2,65	3,93	10,3	1380	6	2,1	10	18	70	1 x 300	230V -1	1340	80	0,36
SPA 041D	3,00	4,44	13,6	1300	5	2,8	12*	22	70	1 x 300	230V -1	1340	80	0,36
SPA 051D	6,05	8,98	20,5	3020	8	4,2	12*	28	77	1 x 400	230V -1	1420	188	0,83
SPA 061D	6,83	10,1	30,6	2720	7	6,3	12*	28	77	1 x 400	230V -1	1420	188	0,83
SPA 071D	11,3	16,8	36,3	5800	17	7,6	15*	35	83	1 x 500	400V -3	1362	560	1,01
SPA 081D	13,1	19,3	54,2	5270	16	11,1	15*	35	83	1 x 500	400V -3	1362	560	1,01
SPA 022D	3,62	5,34	18,2	1520	6	3,6	12*	22	66	2 x 250	230V -1	1347	85	0,59
SPA 032D	5,33	7,90	20,6	2760	8	4,1	12*	28	73	2 x 300	230V -1	1340	80	0,36
SPA 042D	6,02	8,92	27,3	2600	7	5,5	12*	28	73	2 x 300	230V -1	1340	80	0,36
SPA 052D	11,9	17,7	40,9	6040	12	8,2	15*	35	80	2 x 400	230V -1	1420	188	0,83
SPA 062D	13,4	19,7	60,9	5440	11	12,1	15*	35	80	2 x 400	230V -1	1420	188	0,83
SPA 072D	21,7	31,9	72,7	11600	22	14,3	15*	42	86	2 x 500	400V -3	1362	560	1,01
SPA 082D	25,7	37,9	108,3	10540	21	21,5	22*	42	86	2 x 500	400V -3	1362	560	1,01
SPA 023D	5,51	8,16	27,3	2280	8	5,3	12*	28	68	3 x 250	230V -1	1347	85	0,59
SPA 043D	8,96	13,3	40,9	3900	10	8,0	15*	35	75	3 x 300	230V -1	1340	80	0,36
SPA 053D	18,2	27,0	61,4	9060	15	12,0	22*	42	82	3 x 400	230V -1	1420	188	0,83
SPA 063D	20,6	30,4	91,5	8160	13	18,0	22*	42	82	3 x 400	230V -1	1420	188	0,83
SPA 073D	33,4	49,5	109,2	17400	26	21,3	22*	54	88	3 x 500	400V -3	1362	560	1,01
SPA 083D	38,3	56,3	162,7	15810	24	32,2	22*	54	88	3 x 500	400V -3	1362	560	1,01
SPA 024D	7,26	10,7	36,3	3040	9	7,1	12*	28	69	4 x 250	230V -1	1347	85	0,59
SPA 044D	11,7	17,2	54,5	5200	12	10,6	15*	35	76	4 x 300	230V -1	1340	80	0,36
SPA 064D	26,9	39,6	122,0	10880	16	23,7	22*	42	83	4 x 400	230V -1	1420	188	0,83
SPA 074D	43,5	64,1	145,5	23200	28	28,6	22*	54	89	4 x 500	400V -3	1362	560	1,01
SPA 084D	51,6	76,1	216,9	21080	26	41,0	28**	54	89	4 x 500	400V -3	1362	560	1,01
SPA 065D	34,1	50,4	152,4	13600	18	28,9	22*	54	84	5 x 400	230V -1	1420	188	0,83

Multiple injection via * flow distributor, ** KÜBA-CAL® distributor
The technical data are also given in the product selection software.

*** Modification of sound power level, see page 59

Available for CO₂-DX up to 54 bar

Q_v - diagram (R22, R134A, R404A, R507)

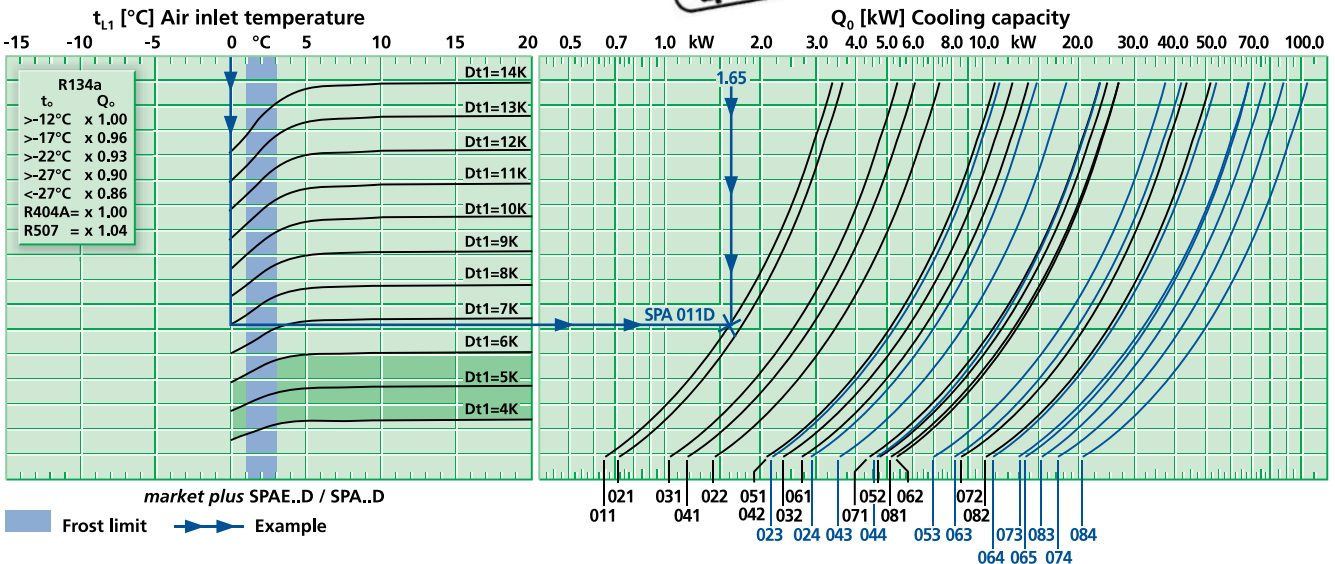



Technical data **SPB(E)...D** 7 mm

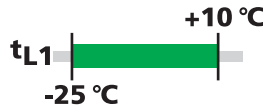

Model	Rating Q_0 at 50 Hz DT1, R404A		Surface m ²	Air flow m ³ /h	Air throw m	Tube volume dm ³	Connections		Sound L_{WA} dB(A)	Blade St. x \emptyset mm	Fans \varnothing (Operating values at 50 Hz)		
	$t_{L1} \pm 0 \text{ °C}$ DT1 = 8K	$t_{L1} +10 \text{ °C}$ DT1 = 10 K					Inlet \emptyset mm	Outlet \emptyset mm			Type of current	Per Fan W A	

Applied for

SPB 011D	⊕	1,28	1,01	4,6	880	4	1,4	10	12	63	1 x 250	230V-1	1347	85	0,59
SPB 021D	⊕	1,51	1,20	6,0	850	4	1,9	10	12	63	1 x 250	230V-1	1347	85	0,59
SPB 031D	⊕	2,03	1,61	6,9	1450	7	2,1	10	18	70	1 x 300	230V-1	1340	80	0,36
SPB 041D	⊕	2,45	1,94	9,1	1420	6	2,8	12*	22	70	1 x 300	230V-1	1340	80	0,36
SPB 051D	⊕	4,78	3,78	13,7	3320	9	4,2	12*	28	77	1 x 400	230V-1	1420	188	0,83
SPB 061D	⊕	5,93	4,70	20,4	3080	8	6,3	12*	28	77	1 x 400	230V-1	1420	188	0,83
SPB 071D	⊕	8,75	6,92	24,3	6250	18	7,6	15*	35	83	1 x 500	400V-3	1362	560	1,01
SPB 081D	⊕	11,1	8,76	36,3	5880	17	11,1	15*	35	83	1 x 500	400V-3	1362	560	1,01
SPB 022D	⊕⊕	3,03	2,41	12,2	1700	6	3,6	12*	22	66	2 x 250	230V-1	1347	85	0,59
SPB 032D	⊕⊕	4,05	3,21	13,7	2900	9	4,1	12*	28	73	2 x 300	230V-1	1340	80	0,36
SPB 042D	⊕⊕	4,89	3,88	18,2	2840	8	5,5	12*	28	73	2 x 300	230V-1	1340	80	0,36
SPB 052D	⊕⊕	9,49	7,52	27,3	6640	13	8,2	15*	35	80	2 x 400	230V-1	1420	188	0,83
SPB 062D	⊕⊕	11,7	9,31	40,7	6160	12	12,1	15*	35	80	2 x 400	230V-1	1420	188	0,83
SPB 072D	⊕⊕	17,1	13,5	48,6	12500	23	14,3	15*	42	86	2 x 500	400V-3	1362	560	1,01
SPB 082D	⊕⊕	21,9	17,4	72,5	11760	22	21,5	22*	42	86	2 x 500	400V-3	1362	560	1,01
SPB 023D	⊕⊕⊕	4,59	3,63	18,2	2550	8	5,3	12*	28	68	3 x 250	230V-1	1347	85	0,59
SPB 043D	⊕⊕⊕	7,31	5,80	27,3	4260	11	8,0	15*	35	75	3 x 300	230V-1	1340	80	0,36
SPB 053D	⊕⊕⊕	14,4	11,4	41,0	9960	16	12,0	22*	42	82	3 x 400	230V-1	1420	188	0,83
SPB 063D	⊕⊕⊕	17,8	14,1	61,1	9240	14	18,0	22*	42	82	3 x 400	230V-1	1420	188	0,83
SPB 073D	⊕⊕⊕	26,0	20,6	73,0	18750	27	21,3	22*	54	88	3 x 500	400V-3	1362	560	1,01
SPB 083D	⊕⊕⊕	32,6	25,9	108,8	17640	25	32,2	22*	54	88	3 x 500	400V-3	1362	560	1,01
SPB 024D	⊕⊕⊕⊕	6,08	4,82	24,3	3400	9	7,1	12*	28	69	4 x 250	230V-1	1347	85	0,59
SPB 044D	⊕⊕⊕⊕	9,63	7,65	36,5	5680	13	10,6	15*	35	76	4 x 300	230V-1	1340	80	0,36
SPB 064D	⊕⊕⊕⊕	23,5	18,7	81,6	12320	17	23,7	22*	42	83	4 x 400	230V-1	1420	188	0,83
SPB 074D	⊕⊕⊕⊕	34,2	27,1	97,1	25000	30	28,6	22*	54	89	4 x 500	400V-3	1362	560	1,01
SPB 084D	⊕⊕⊕⊕	43,8	34,7	144,8	23520	28	41,0	28*	54	89	4 x 500	400V-3	1362	560	1,01
SPB 065D	⊕⊕⊕⊕⊕	29,7	23,5	101,9	15400	19	28,9	22*	54	84	5 x 400	230V-1	1420	188	0,83

Multiple injection via * KÜBA-CAL® distributor

The technical data are also given in the product selection software.

** Modification of sound power level, see page 59



Q_v - diagram (R22, R134A, R404A, R507)

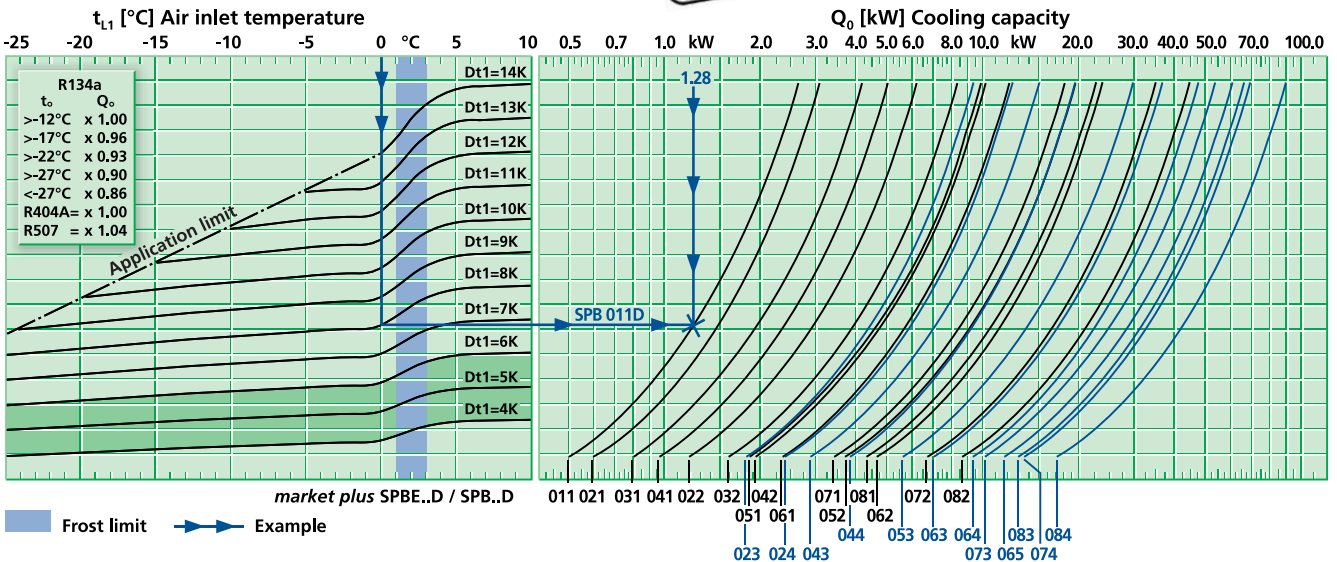



Dimensions, electric defrost, weights

Model	Dimensions [mm]										Electric defrost 230 V-1 / 400 V-3-Y			Weight (net)	
	H	B	T	L	E ₁	E ₂	E ₃	F	A	W	Coil	Tray	Total	SPA.D	SPB.D
	mm	mm	mm	mm	mm	mm	mm	mm	mm	mm	kW	kW	kW	kg	kg
SP. 011D	354	810	424	350	530	-	-	140	92	200	1,07	0,58	1,65	13	12
SP. 021D	354	810	424	350	530	-	-	140	92	200	1,07	0,58	1,65	15	14
SP. 031D	430	970	421	350	630	-	-	170	90	200	1,23	0,69	1,92	18	17
SP. 041D	430	970	421	350	630	-	-	170	90	200	1,23	0,69	1,92	19	18
SP. 051D	509	1180	501	420	780	-	-	200	100	300	2,07	0,88	2,95	27	26
SP. 061D	509	1180	501	420	780	-	-	200	100	300	2,90	0,88	3,78	32	31
SP. 071D	661	1430	592	500	1030	-	-	200	110	400	3,52	0,50	4,02	50	48
SP. 081D	661	1430	592	500	1030	-	-	200	110	400	5,52	0,50	6,02	60	58
SP. 022D	354	1310	424	350	1030	-	-	140	92	200	1,84	0,96	2,80	25	24
SP. 032D	430	1570	421	350	1230	-	-	170	90	200	2,14	1,15	3,29	31	30
SP. 042D	430	1570	421	350	1230	-	-	170	90	200	2,14	1,15	3,29	33	31
SP. 052D	509	1930	501	420	1530	-	-	200	100	300	3,90	1,44	5,34	48	46
SP. 062D	509	1930	501	420	1530	-	-	200	100	300	5,20	1,44	6,64	57	54
SP. 072D	661	2430	592	500	2030	-	-	200	110	400	6,74	0,86	7,60	89	86
SP. 082D	661	2430	592	500	2030	-	-	200	110	400	10,11	0,86	10,97	109	105
SP. 023D	354	1810	424	350	1530	-	-	140	92	200	2,60	1,30	3,90	35	33
SP. 043D	430	2170	421	350	1830	-	-	170	90	200	3,18	1,59	4,77	46	43
SP. 053D	509	2680	501	420	2280	750	-	200	100	300	5,63	1,95	7,58	70	67
SP. 063D	509	2680	501	420	2280	750	-	200	100	300	7,50	1,95	9,45	84	80
SP. 073D	661	3430	592	500	3030	1000	-	200	110	400	9,20	1,82	11,02	136	132
SP. 083D	661	3430	592	500	3030	1000	-	200	110	400	13,80	1,82	15,62	164	159
SP. 024D	354	2310	424	350	2030	1000	-	140	92	200	3,37	1,72	5,09	46	43
SP. 044D	430	2770	421	350	2430	1200	-	170	90	200	4,00	2,00	6,00	59	55
SP. 064D	509	3430	501	420	3030	1500	-	200	100	300	9,20	1,82	11,02	116	111
SP. 074D	661	4430	592	500	4030	2000	-	200	110	400	12,72	2,39	15,11	178	173
SP. 084D	661	4430	592	500	4030	2000	-	200	110	400	19,08	2,39	21,47	221	215
SP. 065D	509	4180	501	420	3780	1500	2250	200	100	300	11,92	2,24	14,16	146	141



Dimensional drawings

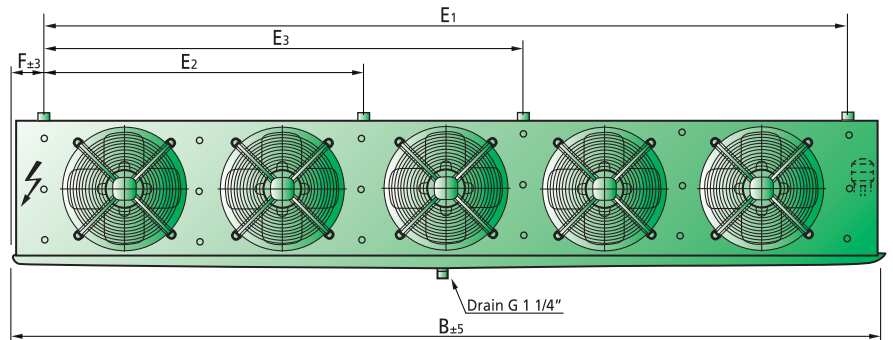
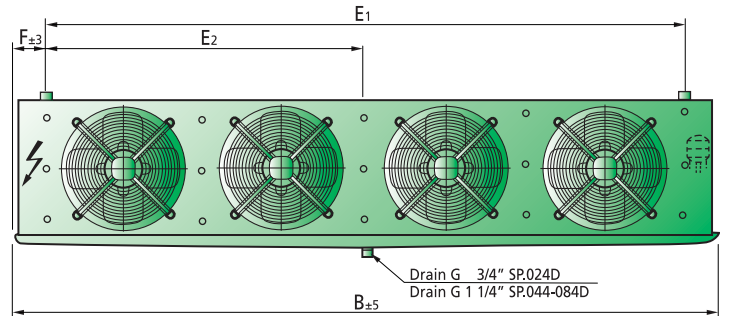
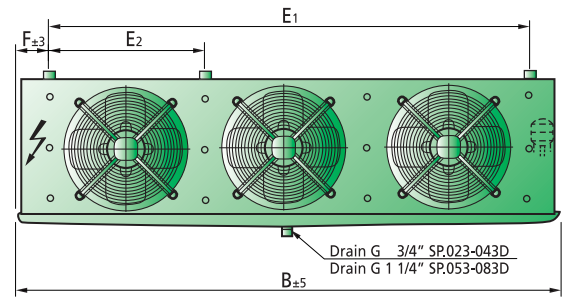
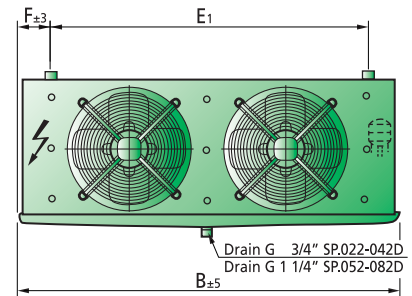
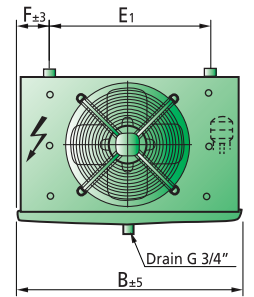
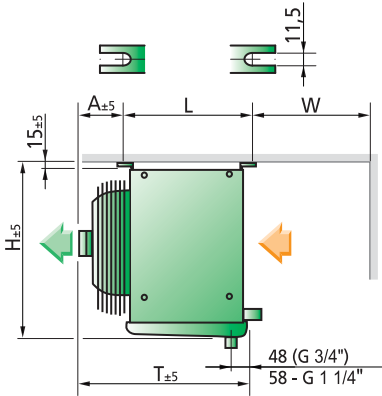



Constructions and Accessories

Water / brine operation

Please use our Küba selection software for configuring the brine Air Coolers. Do not hesitate to contact us if you have any further questions.

Configuration

- Soldered connections
- Ventilation and drainage

Corrosion protection

- Version .V6.01 and .V6.04
 - Cooler
 - Tubes: Copper
 - Fins: Al „goldlack“ coating
 - End plates: Aluminium, anti-corrosion paint coating on both sides (V6.01) Aluminium (V6.04)
 - Casing
 - Aluminium or Sendzimir zinc-plated steel, anti-corrosion paint coating on both sides (V6.01) Aluminium, anti-corrosion paint coating (V6.04)

Küba Air Jet

Advantages

- Longer air throw
- Even temperature distribution in cooled room



Loose as accessory



In mounted condition

Information:

Delivered not fitted
(Cannot be used in conjunction with electrical radiator SPHR)

For Model	Air Jet
	Ø mm
SP. 031D-044D	300
SP. 051D-065D	400
SP. 071D-084D	500



Accessories

Adapter for textile hose connection

Advantages

- Even cooling without draughts
- Even temperature distribution
- Best possible comfort in workrooms of all kinds

Information:

Delivered not fitted
(Cannot be used in conjunction with electrical radiator SPHR)

For Model	Adapter
	Ø mm
SP. 031D-044D	320
SP. 051D-065D	420
SP. 071D-084D	520

Shut-Up® with Küba Air Jet

Advantages

- Reduces defrosting time by more than 40%
- With Shut-Up®, the defrosting heat is kept where it should be – in the Air Cooler
- For electrical defrosting and hot gas defrosting

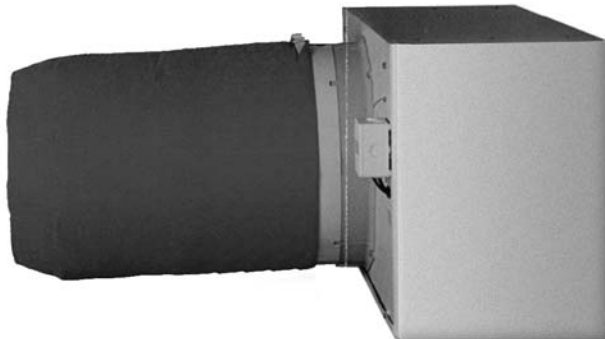

Cooling phase, fans switched on:
Shut-Up® is inflated

Für Model	Shut-Up®
	Ø mm
SP. 031D-044D	320
SP. 051D-065D	420
SP. 071D-084D	520

Information:

Delivered not fitted
(Cannot be used in conjunction with electrical radiator SPHR)



Important note:

Using a fabric tube reduces the air volume and performance.



Defrosting, fans switched off:
Shut-Up® locks the Air Cooler

Important note:

1. Using a textile hose as well as a Shup-Up® reduces the air volume and performance.
2. Using a textile hose as well as a Shup-Up® requires the use of the Küba AIR JET and an adapter (see above).



Accessories

Finned tube heater SPHR

- For Air Coolers with sucking fans for installation by the client

Note:

Do not operate unless Air Cooler fans are running, to prevent the fans and cold room ceiling overheating! Only use in conjunction with standard fan guard!

Scope of delivery

- Electrical finned tube radiator CrNi steel Ø 28 mm
- Connection ends 1000 mm long
- Fastening material Al, Nirosta
- Branching box acc. to VDE, ÖVE, SEV

Model	For Blade Ø mm	Nominal power at 230V kW	Weight kg	Dimensions mm
SPHR25	250	1,36	0,65	245
SPHR30	300	1,75	0,75	300
SPHR40	400	2,47	0,94	400
SPHR50	500	3,19	1,13	500



Model	Order quantity	Rated power per unit at 230V kW
SP. 011D	1x SPHR25	1,36
SP. 021D	1x SPHR25	1,36
SP. 031D	1x SPHR30	1,75
SP. 041D	1x SPHR30	1,75
SP. 051D	1x SPHR40	2,47
SP. 061D	1x SPHR40	2,47
SP. 071D	1x SPHR50	3,19
SP. 081D	1x SPHR50	3,19
SP. 022D	2x SPHR25	2,72
SP. 032D	2x SPHR30	3,50
SP. 042D	2x SPHR30	3,50
SP. 052D	2x SPHR40	4,94
SP. 062D	2x SPHR40	4,94
SP. 072D	1x SPHR50	6,38
SP. 082D	1x SPHR50	6,38
SP. 023D	3x SPHR25	4,08
SP. 043D	3x SPHR30	5,25
SP. 053D	3x SPHR40	7,41
SP. 063D	3x SPHR40	7,41
SP. 073D	3x SPHR50	9,57
SP. 083D	3x SPHR50	9,57
SP. 024D	4x SPHR25	5,44
SP. 044D	4x SPHR30	7,00
SP. 064D	4x SPHR40	9,88
SP. 074D	4x SPHR50	12,76
SP. 084D	4x SPHR50	12,76
SP. 065D	5x SPHR40	12,35



Accessories

Wall Bracket

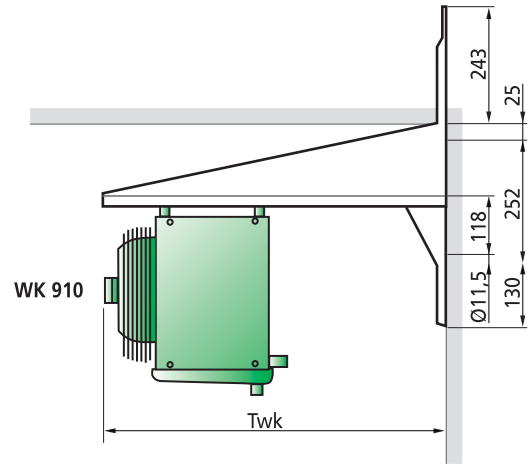
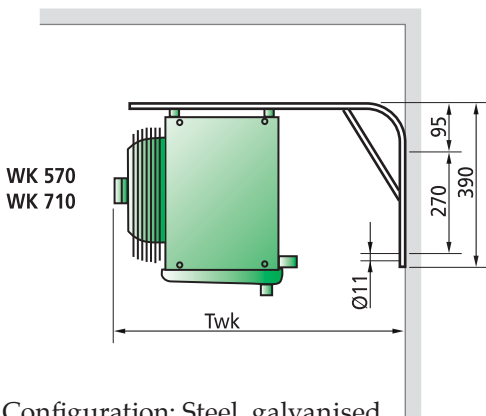

Configuration: Steel, galvanised

For Air Cooler	Model	Dimension Twk	Weight/piece
		mm	kg
SP. 011-044D	WK 570	570	1,80
SP. 051-065D	WK 710	700	2,10
SP. 071-084D	WK 910	910	4,60

Model	Order quantity
SP. 011D-041D	2x WK 570
SP. 051D-061D	2x WK 710
SP. 071D-081D	2x WK 910
SP. 022D-042D	2x WK 570
SP. 052D-062D	2x WK 710
SP. 072D-082D	2x WK 910
SP. 023D-043D	2x WK 570
SP. 053D-063D	3x WK 710
SP. 073D-083D	3x WK 910
SP. 024D-044D	3x WK 570
SP. 064D	3x WK 710
SP. 074D-084D	3x WK 910
SP. 065D	4x WK 710

Mounting set for hinged drip tray

For Air Cooler	Order quantity
SP. 011-081D	2x Set
SP. 022-082D	3x Set
SP. 023-083D	4x Set
SP. 024-084D	5x Set
SP. 065D	6x Set

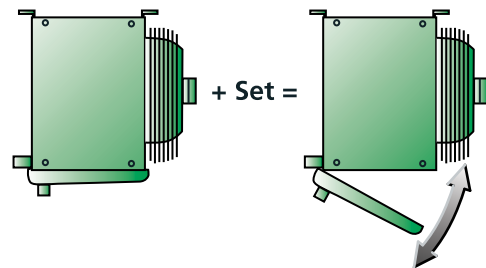

The standard drip tray can be converted to a hinged version without difficulty using the mounting set.